

Code No: 151AD**JAWAHARLAL NEHRU TECHNOLOGICAL UNIVERSITY HYDERABAD****B.Tech I Year I Semester Examinations, March/April - 2023****ENGINEERING GRAPHICS****(Common to CE, ME, EIE, MCT, MMT, AE, MIE, PTM, CSE(AI&ML), CSE(IOT))****Time: 3 hours****Max. Marks: 75****Answer any five questions****All questions carry equal marks**

- - -

1. Draw an epicycloid having a generating circle of diameter 50 mm and directing curve of radius 100 mm. Draw a tangent and a normal at any point on the curve. [15]

OR

2. Construct a diagonal scale of R.F 3:90 to show meters, decimeters and centimeters and to measure upto 4 m. show a distance of 2m, 3 dm and 5 cm on the scale. [15]

3. A 100 mm long line EF has 70 mm length in the top view and 84 mm length in the front view. If the line end E is 20 mm above HP and F is 15 mm in front of VP, find the true length of the line EF and draw the projections. [15]

OR

4. A hexagonal lamina of 30 mm side stands with one of its edges parallel to and 20 mm in front of VP, such that the surface is inclined at 45° to VP. If the edge parallel to VP is inclined at 50° to HP, draw the projections of the lamina. [15]

5. A cone of base 50 mm diameter and axis 60 mm long has one of its generators on HP. If the axis is parallel to VP, draw its projections. [15]

OR

6. A square pyramid of side 50 mm and height 70 mm is kept on HP so that the sides are equally inclined to VP. A cutting plane perpendicular to VP but inclined at 60° to HP cuts and removes the apex portion so that the plane passes through the midpoint of the axis in the front view. Draw the front view, sectional top view and the true shape of the section. [15]

7. A right regular pentagonal pyramid, side of base 36 mm and height 64 mm, rests on its base upon the ground with one of its base side parallel to VP. A sectional plane perpendicular to VP and inclined at 30° to HP cuts the pyramid, bisecting its axis. Draw the development of the truncated pyramid. [15]

OR

8. A vertical cylinder of 72 mm diameter and 100 mm length is penetrated by another cylinder, 48 mm diameter and 120 mm long. The axis of the penetrating cylinder is inclined at 25° to HP and parallel to VP. Draw the projections showing the line of intersection, if the two axes of the cylinders intersect at their mid points. [15]

9. A cone of diameter 32 mm base and 40 mm height is surmounted over a square slab of 40 mm side and base 25 mm thickness on HP so that one edge of the square is parallel to VP. Draw the isometric view of the combination. [15]

OR

10. Draw the front, top and side view of the following machine part.

[15]

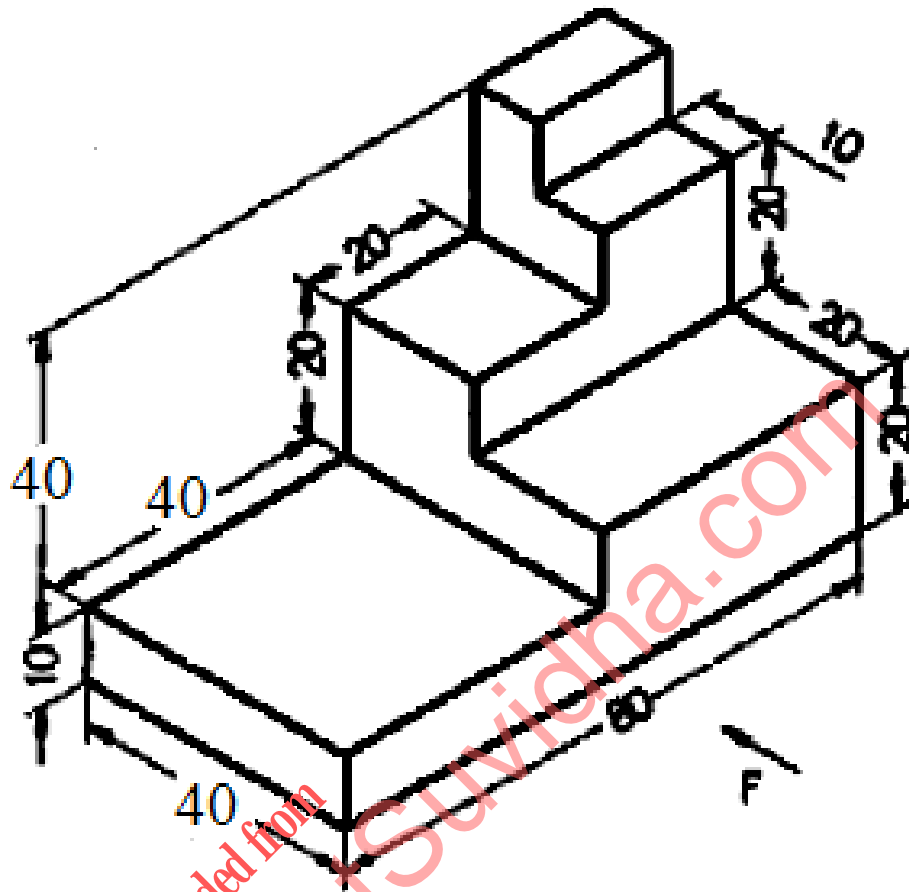

--ooOoo--